



- Simplified user interface
- Robust & compact design
- Perfect visibility with slidable seats
- High efficiency drive train
- Perfect traction

## TECHNICAL DATA

### MASSES

Mass (incl. standard screed) 10.5 t

### DIMENSIONS

Working width, hydraulic extendable 3.50 m  
 Working width, maximum (incl. extension boxes) 4.70 m  
 Working width, minimum (with reducing shoe) 0.70 m  
 Front ramp angle 15°  
 Rear ramp angle 13°

### CAPACITY

Placement thickness, min/max -120 /200 mm  
 Theoretical placement capacity 350 t/h

### MATERIAL HOPPER

Capacity 10.5 t  
 Hopper width, internal 3040 mm  
 Dumping height, center 520 mm

### OPERATION

Operational controls Conventional

### TRACTION

Maximum paving speed 25 m/min  
 Transport speed 4 km/h

### ENGINE

Manufacturer/Model Deutz, 2.9L TD 4-Cylinder  
 Rated power 50 kW @ 2200 rpm  
 Emissions according to Stage V /Tier 3  
 Electrical system 24 V  
 Fuel tank capacity 73 l

### UNDERCARRIAGE

Final drive Hydrostatic  
 Crawler length 2090 mm  
 Crawler width 260 mm

### CONVEYOR

Conveyor control Proportional speed control, Both sides driven independently, Reversible  
 Conveyor type Dual bar feeder  
 Conveyor width 700 mm

### AUGER

Auger control Proportional speed control, Both sides driven independently  
 Auger diameter 320 mm  
 Auger height adjustment 200 mm

Find us locally at [www.dynapac.com](http://www.dynapac.com)

We reserve the right to change specifications without notice. Photos and illustrations do not always show standard versions of machines. The above information is a general description only, all informations are supplied without liability.



- Simplified user interface
- Robust & compact design
- Perfect visibility with slidable seats
- High efficiency drive train
- Perfect traction

## DIMENSIONS

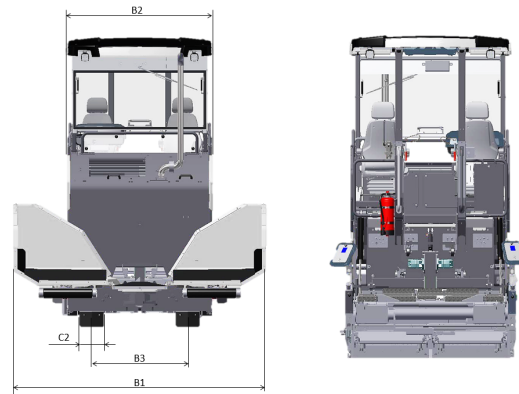
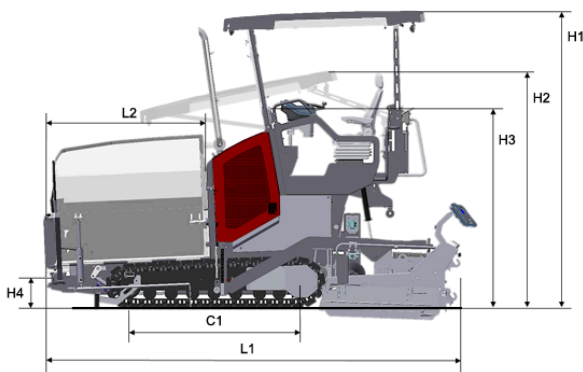

### DIMENSIONS

B1. Width, max.	3.15 m
B2. Width, standard	1.80 m
B3. Width, center of tracks	1.20 m
C1. Track length	2.09 m
C2. Track width	0.26 m
H1. Height, max.	3.60 m
H2. Height, transport	2.92 m
H3. Height	2.40 m
H4. Dumping height	0.50 m
L1. Length	4.99 m
L2. Length, hopper	1.99 m

Find us locally at [www.dynapac.com](http://www.dynapac.com)

We reserve the right to change specifications without notice. Photos and illustrations do not always show standard versions of machines. The above information is a general description only, all informations are supplied without liability.

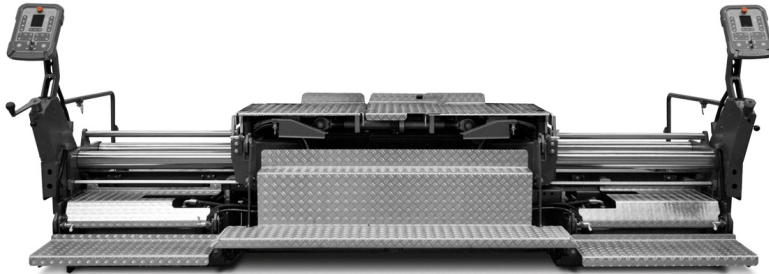

## COMPATIBLE SCREEDS

### V3500 V / V E / TV / TV E

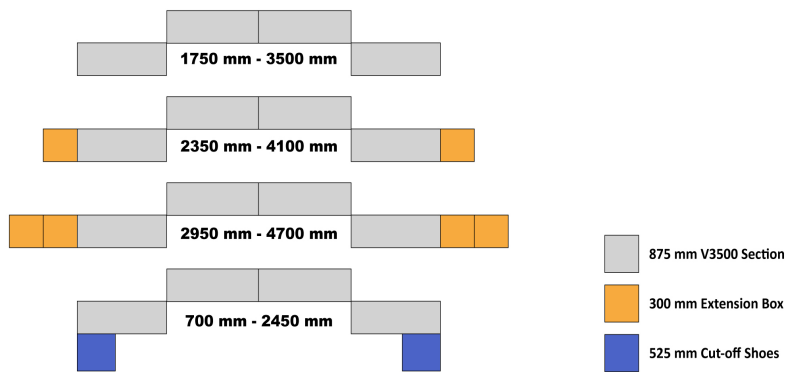

Find us locally at [www.dynapac.com](http://www.dynapac.com)

We reserve the right to change specifications without notice. Photos and illustrations do not always show standard versions of machines. The above information is a general description only, all informations are supplied without liability.