



## TECHNICAL DATA

### MASSES

Operating mass (incl. ROPS)	11800 kg
Operating mass (incl. Cab)	11900 kg
Operating mass (incl. Canopy)	11700 kg
Module mass (front/rear)	7000/4900 kg
Max. operating mass	12000 kg

### COMPACTION

Nominal amplitude (high/low)	2.0/1.1 mm
Vibration frequency (high/low amplitude)	30/30 Hz
Centrifugal force (high/low amplitude)	270/150 kN

### TRACTION

Speed range: Single Speed/Dual Speed/Traction Control	8 /8 /11 km/h
Vertical oscillation	±9°
Number of pads	130
Pad area	146 cm <sup>2</sup>

### HYDRAULIC SYSTEM

Driving	Hydrostatic
Vibration	Hydrostatic
Steering	Hydrostatic
Service brake	Hydrostatic in forward and reverse lever.
Parking/ Emergency brake	Failsafe multidisc brake in rear axle and front drum motor.

### ENGINE

Manufacturer/Model	Cummins QSF3.8 (III A/T3)
Type	Water cooled turbo Diesel
Rated power, SAE J1995	97 kW (130 hp) @ 2500 rpm
Fuel tank capacity	280 l
Electrical system	12 V

### ENGINE

Manufacturer/Model	Cummins 4BT3.9-102C (I/T1)
Type	Water cooled Diesel
Rated power, SAE J1995	76 kW (102 hp) @ 2300 rpm
Fuel tank capacity	280 l
Electrical system	12 V

Find us locally at [www.dynapac.com](http://www.dynapac.com)

We reserve the right to change specifications without notice. Photos and illustrations do not always show standard versions of machines. The above information is a general description only, all information's are supplied without liability.

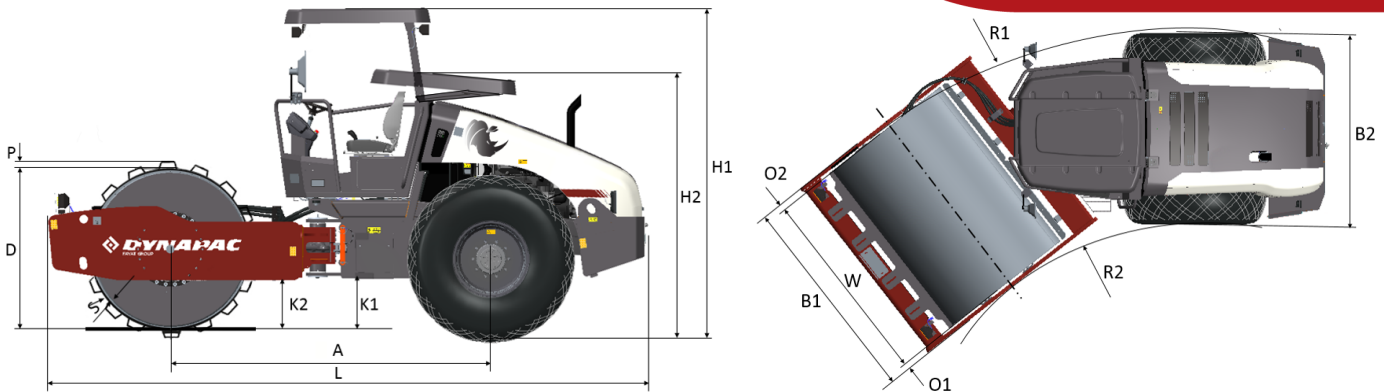

## DIMENSIONS

### DIMENSIONS

A. Wheelbase	2990 mm
B1. Width, front	2256 mm
B2. Width, rear	2130 mm
D. Drum diameter	1694 mm
H1. Height, with ROPS/cab	2890 mm
H2. Height, w/o ROPS/cab	2400 mm
K1. Ground clearance	460 mm
K2. Curb clearance	460 mm
L. Length	5560 mm
O1. Overhang, right	63 mm
O2. Overhang, left	63 mm
P. Pad height	102 mm
R1. Turning radius, outside	5650 mm
R2. Turning radius, inside	3255 mm
S. Drum shell thickness	20 mm
W. Drum width	2130 mm
$\alpha$ . Steering angle	$\pm 38^\circ$

### STANDARD EQUIPMENT

- 12 V outlet (IIIA/T3 only)
- Amplitude, dual
- AVC Automatic Vibration Control
- Back-up alarm
- Battery switch
- Brake release
- Emergency stop
- Filler caps lockable
- Fuel level gauge
- Fuel tank drainage
- Hood, lockable
- Horn
- Hour meter
- Hydraulic check-points
- Interlock
- Lifting points
- Neutral start arrangement
- Operator's platform
- vibration dampened
- Operator's seat
- adjustable forward&reverse
- Operator's station
- fixed
- Parking brake
- Rear axle Limited slip (Single & Dual Speed)
- Rear axle No-spin (Traction Control)
- Scraper
- fixed steel
- smooth (high mounted)
- Seat belt 2", (not Open Platform)
- Service indicators/warnings
- Storage box on operator's platform
- Tie-down points
- Tool boxes
- integrated in fenders
- User's instructions
- one set
- Vandal cover (over instrument panel)
- Vibration quick-stop

### OPTIONAL EQUIPMENT

- 50 hours Service kit
- Bolt-on padfoot shell
- CA25D/30D
- Compaction Meter (CMV) with tilt & gradeability indicator
- Extra set of user's instruction
- First aid box
- Lights
- driving
- left hand traffic
- right hand traffic
- Operator's seat
- adjustable comfort
- Operator's station
- rotating
- Radio with MP3 (Cab)
- Rear view mirrors
- traffic view
- Remote monitoring
- Dyn@Link
- Rotating beacon
- fixed steel
- smooth (low mounted)
- Scrapers (dual), flexible
- smooth (low mounted)
- Scrapers
- fixed steel, pads
- Speedometer including pass counter
- Tool set

Find us locally at [www.dynapac.com](http://www.dynapac.com)

We reserve the right to change specifications without notice. Photos and illustrations do not always show standard versions of machines. The above information is a general description only, all information's are supplied without liability.