



TECHNICAL DATA

MASSES

Max. operating mass	1750 kg
Operating mass (incl. ROPS)	1685 kg
Module mass (front/rear)	790 kg/895 kg

COMPACTION

Centrifugal force	17 kN
Nominal amplitude	0.4 mm
Static linear load (front/rear)	7.9/8.9 kg/cm
Vibration frequency	70 Hz
Water tank	190 l

TRACTION

Speed range	0-9 km/h
Vertical oscillation	±13°

ENGINE

Manufacturer/Model	Kubota D1105-E4B T4f/V
Type	Water cooled diesel
Rated power, SAE J1995	18 kW (24 hp) @ 2800 rpm
Fuel tank capacity	23 l

HYDRAULIC SYSTEM

Driving	Axial piston pump with variable displacement and servo. 2 radial piston motors with constant displacement.
Vibration	Gear pump/motors with constant displacement.
Steering	Gear pump with constant displacem.
Service brake	Hydrostatic in forward and reverse lever.
Parking/ Emergency brake	Failsafe brake in both drums.

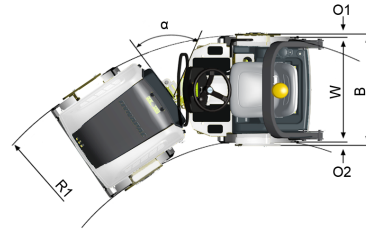
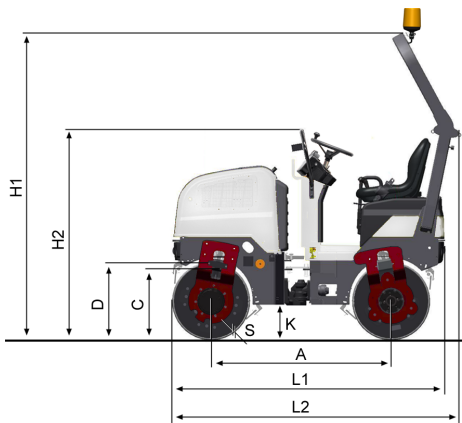

TECHNICAL DATA

DIMENSIONS

A. Wheelbase	1350 mm
B. Width	1070 mm
C. Curb clearance	465 mm
D. Drum diameter	584 mm
H2. Height, w/o ROPS/cab	1585 mm
K. Ground clearance	250 mm
L1. Length	2040 mm
L2. Length (ROPS)	2095 mm
O1. Overhang, right	35 mm
O2. Overhang, left	35 mm
R1. Turning radius, outside	2860 mm
S. Drum shell thickness	12 mm
W. Drum width	1000 mm
α. Steering angle	±34°

STANDARD EQUIPMENT

- Auto Vibration Ctrl (AVC)
- Auto Water Ctrl (AWC)
- Back up alarm, Central lifting eye
- Cup/Can holder, Emergency stop
- Foldable ROPS, Fuel gauge
- Horn, Hourmeter
- Hydraulic pressure checkpoints
- Ignition key, Interlock brake
- Pressurized sprinkler system
- Rubber mounted operator's platform
- Seat belt, Sprinkler timer
- Towing eyelet front/rear
- Vibration both drums
- Warning lights;
- Brake -Charging -Engine oil pressure/ water temp -Low fuel

OPTIONAL EQUIPMENT

- Biodegradable hydraulic fluid
- Cert. fire protection (SBF 127)
- Decal risk location (GOST)
- Fire extinguisher, Hearing protectors
- Licence plate light
- Rear view mirror (traffic view)
- Service kit 50/500/1000 h
- Side direction lights (driving lights required)
- Slow moving vehicle sign
- Special color (one or two)
- Tool set, Water tank cover (lockable)