



TECHNICAL DATA

MASSES

Max. operating mass	4030 kg
Operating mass (incl. ROPS)	3900 kg
Module mass (front/rear)	1900 kg/2000 kg

COMPACTION

Centrifugal force	33 kN (V2203) /36 kN (D1803)
Nominal amplitude	0.5 mm
Static linear load (front/rear)	14.6/15.4 kg/cm
Vibration frequency	52 Hz (V2203) /53 Hz (D1803)
Water tank	200 l

TRACTION

Speed range	0-10 km/h
Vertical oscillation	±10°
Max. theoretical gradeability	37 %

ENGINE

Manufacturer/Model	Kubota V2203-M (IIIA)
Type	Water cooled diesel engine
Rated power, SAE J1995	33 kW (44 hp) @ 2600 rpm
Fuel tank capacity	50 l

ENGINE

Manufacturer/Model	Kubota D1803-CR-TE4B(T4f)
Type	Water cooled diesel engine
Rated power, SAE J1995	37 kW (49 hp) @ 2700 rpm

ENGINE

Model	Kubota D1803-CR-TE5B(StageV)
Type	Water cooled diesel engine
Rated power, SAE J1995	37 kW (49 hp) @ 2700 rpm

HYDRAULIC SYSTEM

Driving	Axial piston pump with variable displacement. Radial piston motors (2) with constant displacement.
Vibration	Gear pump/motors with constant displacement.
Steering	Gear pump with constant displacem.
Service brake	Hydrostatic in forward and reverse lever.
Parking/ Emergency brake	Failsafe multidisc brake in both drums.

Find us locally at www.dynapac.com

We reserve the right to change specifications without notice. Photos and illustrations do not always show standard versions of machines.
The above information is a general description only, all information's are supplied without liability.

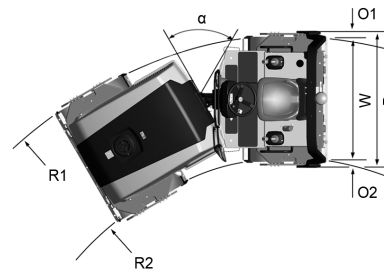
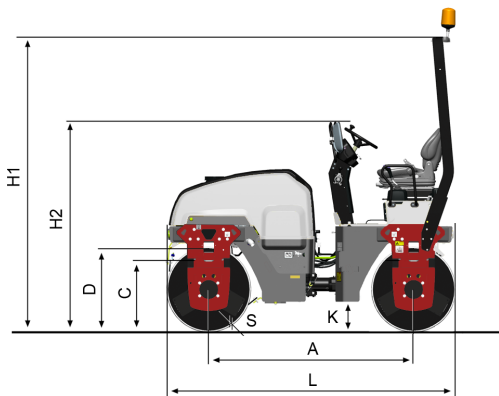

TECHNICAL DATA

DIMENSIONS

A. Wheelbase	1925 mm
B. Width	1450 mm
C. Curb clearance	600 mm
D. Drum diameter	802 mm
H1. Height, with ROPS/cab	2750 mm
H2. Height, w/o ROPS/cab	1855 mm
K. Ground clearance	260 mm
L. Length	2725 mm
O1. Overhang, right	50 mm
O2. Overhang, left	50 mm
R1. Turning radius, outside	4240 mm
R2. Turning radius, inside	2940 mm
S. Drum shell thickness	16 mm
W. Drum width	1300 mm
α. Steering angle	±30°

OPTIONAL EQUIPMENT

- 3" seatbelt, Biodegradable hydraulic fluid
- Cert. Fire protection (SBF 127)
- Decal risk location (GOST)
- Driving lights (right and left handed). Dual forward/reverse control
- Fire extinguisher, Flow divider, Foot rest
- Hearing protectors, Service kit 50/500/1000H
- Licence plate light, Rear view mirror (traffic view)
- Rotating beacon (ignition controlled)
- Side direction lights (driving lights required)
- Slide lux seat, Slow moving vehicle sign
- Special color (one or two)
- Spring loaded scrapers, Tool set
- Towing eyelet, Water tank cover (lockable)

EQUIPMENT PACKAGE

CC Plus Package	Included	Optional
Backup alarm	■	
Brake release	■	
CE sign	■	
Driving lights, right or left handed		■
Dual arm rest	■	
Dual forward/reverse control		■
Flow divider		■
Foldable ROPS incl. seatbelt	■	
Rotating beacon	■	
Rotating beacon, ignition controlled		■
Slideable comfort seat	■	
Slideable lux seat		■
Spring loaded scrapers		■
Sprinkler timer	■	
Vibr. shut off, front and rear drum	■	
Working lights	■	

Find us locally at www.dynapac.com

We reserve the right to change specifications without notice. Photos and illustrations do not always show standard versions of machines. The above information is a general description only, all information's are supplied without liability.