



- Operator station -slidable, 180 deg or full rotation
- Touch screen display -moves with the seat
- 4-3-2 full back-up water sprinkler system



## TECHNICAL DATA

### MASSES

Max. operating mass	10700 kg
Operating mass (incl. ROPS)	9200 kg
Operating mass (incl. Cab)	9350 kg
Module mass (front/rear)	4800 kg/4400 kg

### COMPACTION

Centrifugal force (high/low amplitude)	84 kN /72 kN
Nominal amplitude (high/low)	0.7 mm/0.3 mm
Static linear load (front/rear)	28.6/26.2 kg/cm
Vibration frequency (high/low amplitude)	48 Hz/67 Hz
Water tank volume	750 l

### TRACTION

Speed range	0 -12 km/h
Vertical oscillation	±6°
Max. theoretical gradeability	38 %

### ENGINE

Manufacturer/Model	Cummins QSB 3.3 IIIA/T3
Type	Water cooled turbo Diesel
Rated power, SAE J1995	74kW (99hp) @ 2200 rpm
Fuel tank capacity	130 l

### HYDRAULIC SYSTEM

Driving	Axial piston pump with variable displacem. Rad. piston motors(2) with variable displacem.
Vibration	Axial piston pumps(2) with variable displacem. Axial piston motors(2) with const. displacem.
Steering	Gear pump with constant displacem.
Service brake	Hydrostatic in forward and reverse lever.
Parking/ Emergency brake	Failsafe multidisc brake in both drums.

Find us locally at [www.dynapac.com](http://www.dynapac.com)

We reserve the right to change specifications without notice. Photos and illustrations do not always show standard versions of machines. The above information is a general description only, all information's are supplied without liability.

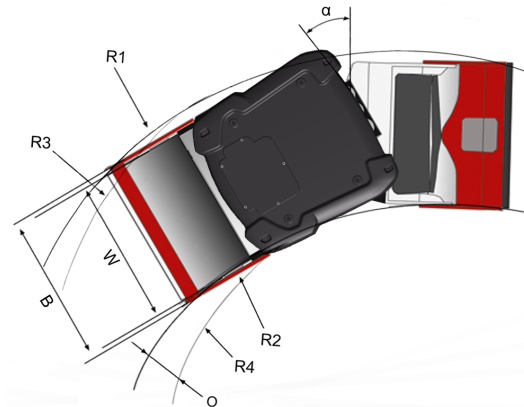
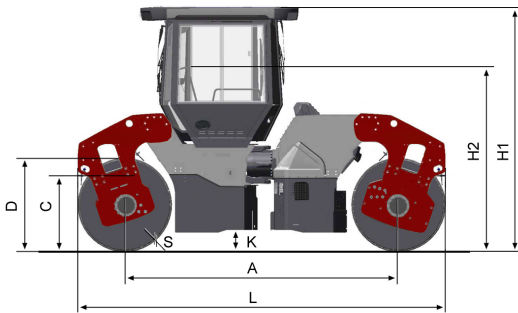

## DIMENSIONS

### DIMENSIONS

A. Wheelbase	3,340 mm
B. Width	1860 mm
B2. Width, with cab	2020 mm
C. Curb clearance	580 mm
D. Drum diameter	1150 mm
H1. Height, with ROPS/cab	2990 mm
K. Ground clearance	270 mm
L. Length	4460 mm
R1. Turning radius, outside	6690 mm
R2. Turning radius, inside	5010 mm
R3. Turning radius with off-set, outside	5000 mm
R4. Turning radius with off-set, inside	3320 mm
S. Drum shell thickness	20 mm
W. Drum width	1680 mm
$\alpha$ . Steering angle	$\pm 32^\circ$

### OPTIONAL EQUIPMENT

#### Air Conditioning /Automatic Climate Control (ACC) (Optional)

- The system contains fluorinated greenhouse gases.
- Coolant designation: HFC-134a
- Coolant weight when full: 1,35 kg
- CO<sub>2</sub>-equivalent: 1,930 ton
- GWP: 1430

Find us locally at [www.dynapac.com](http://www.dynapac.com)

We reserve the right to change specifications without notice. Photos and illustrations do not always show standard versions of machines. The above information is a general description only, all information's are supplied without liability.