



- Operator station -slidable, 180 deg or full rotation
- Touch screen display -moves with the seat
- 4-3-2 full back-up water sprinkler system
- 520 mm optional drum offset



TECHNICAL DATA

MASSES

Max. operating mass	13150 kg
Operating mass (incl. ROPS)	10000 kg
Module mass (front/rear)	5000 kg/5000 kg

COMPACTION

Centrifugal force (high/low amplitude)	128 kN/84 kN
Nominal amplitude (high/low)	0.8 mm /0.3 mm
Static linear load (front/rear)	29.8 kg/cm /29.8 kg/cm
Vibration frequency (high/low amplitude)	51 Hz/67 Hz
Water tank volume	680 liters /(880 liters w. opt. watert.)
Water tank volume (front drum steering)	740 liters

COMPACTION (CE)

Centrifugal force (high/low amplitude)	113 kN/69 kN
Vibration frequency (high/low amplitude)	48 Hz/61 Hz

TRACTION

Speed range	0-12 km/h
Vertical oscillation	±7°
Max. theoretical gradeability	40 %

ENGINE

Manufacturer/Model	Cummins F3.8 V
Type	Water cooled turbo diesel
Rated power, SAE J1995	100 kW (135 hp) @ 2200 rpm
Fuel tank capacity	180 l
DEF tank capacity	15 l

ENGINE

Manufacturer/Model	Cummins QSF 3.8 IV/T4f
Type	Water cooled turbo diesel
Rated power, SAE J1995	97 kW (130 hp) @ 2200 rpm

ENGINE

Manufacturer/Model	Cummins QSF 3.8 IIIA/T3
Type	Water cooled turbo diesel
Rated power, SAE J1995	104 kW (140 hp) @ 2200 rpm

HYDRAULIC SYSTEM

Driving	Axial piston pump with variable displacem. Rad. piston motors(2) with variable displacem.
Vibration	Axial piston pumps(2) with variable displacem. Axial piston motors(2) with const. displacem.
Steering	Gear pump with constant displacem.
Service brake	Hydrostatic in forward and reverse lever.
Parking/ Emergency brake	Failsafe multidisc brake in both drums.

Find us locally at www.dynapac.com

We reserve the right to change specifications without notice. Photos and illustrations do not always show standard versions of machines. The above information is a general description only, all information's are supplied without liability.

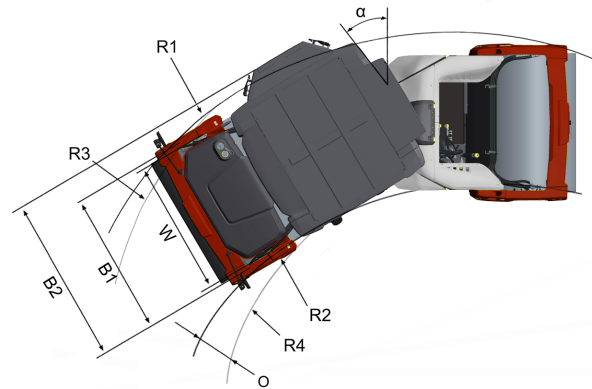
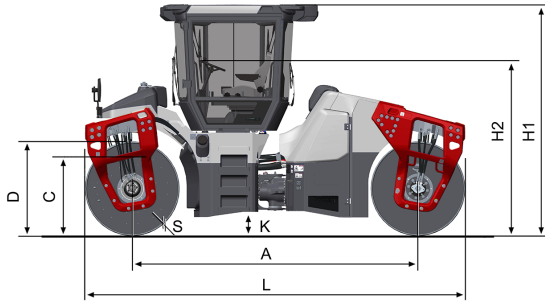

DIMENSIONS

DIMENSIONS

A. Wheelbase	3760 mm
B1. Width, front	1910 mm
B2. Width, with cab	2140 mm
C. Curb clearance	815 mm
D. Drum diameter	1300 mm
H. Height, with ROPS/cab	2990 mm
K. Ground clearance	310 mm
L. Length	5060 mm
O. Off-set	520 mm
R1. Turning radius, outside	7270 mm
R2. Turning radius, inside	5590 mm
R3. Turning radius with off-set, outside	5460 mm
R4. Turning radius with off-set, inside	3780 mm
S. Drum shell thickness	20 mm
W. Drum width	1680 mm
α . Steering angle	$\pm 32^\circ$

OPTIONAL EQUIPMENT

Air Conditioning /Automatic Climate Control (ACC) (Optional)

- The system contains fluorinated greenhouse gases.
- Coolant designation: HFC-134a
- Coolant weight when full: 1,6 kg
- CO₂-equivalent: 2,288 ton
- GWP: 1430

Find us locally at www.dynapac.com

We reserve the right to change specifications without notice. Photos and illustrations do not always show standard versions of machines. The above information is a general description only, all information's are supplied without liability.