



TECHNICAL DATA

MASSES

Max. operating mass	1665 kg
Operating mass (incl. ROPS)	1600 kg
Module mass (front/rear)	750 kg/850 kg

COMPACTION

Centrifugal force	17 kN
Nominal amplitude	0.4 mm
Static linear load (front/rear)	8.3/9.4 kg/cm
Vibration frequency	70 Hz
Water tank	190 l

TRACTION

Speed range	0-9 km/h
Vertical oscillation	±13°

ENGINE

Manufacturer/Model	Kubota D1105-E4B T4f/V
Type	Water cooled diesel
Rated power, SAE J1995	18 kW (24 hp) @ 2800 rpm
Fuel tank capacity	23 l

HYDRAULIC SYSTEM

Driving	Axial piston pump with variable displacement and servo. 2 radial piston motors with constant displacement.
Vibration	Gear pump/motors with constant displacement.
Steering	Gear pump with constant displacem.
Service brake	Hydrostatic in forward and reverse lever.
Parking/ Emergency brake	Failsafe brake in both drums.

Find us locally at www.dynapac.com

We reserve the right to change specifications without notice. Photos and illustrations do not always show standard versions of machines. The above information is a general description only, all information's are supplied without liability.

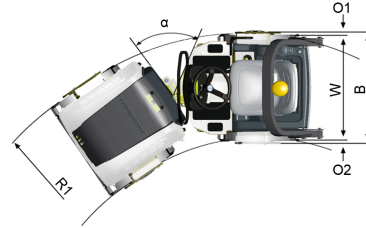
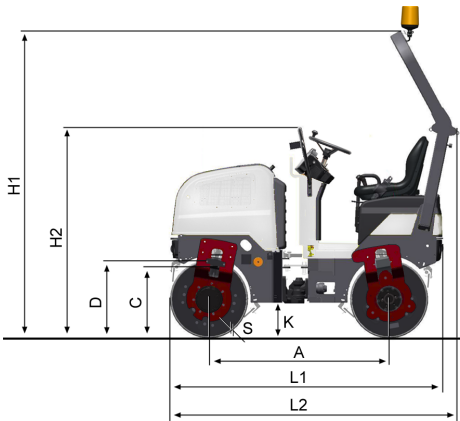

TECHNICAL DATA

DIMENSIONS

A. Wheelbase	1350 mm
C. Curb clearance	465 mm
D. Drum diameter	584 mm
H1. Height, with ROPS/cab	2300 mm
K. Ground clearance	255 mm
L1. Length	2040 mm
W. Drum width	900 mm
α. Steering angle	±34°

OPTIONAL EQUIPMENT

- 3" seatbelt
- Biodegradable hydraulic fluid
- Cert. fire protection (SBF 127)
- Decal risk location (GOST)
- Fire extinguisher
- Hearing protectors
- Licence plate light
- Rear view mirror (traffic view)
- Service kit 50/500/1000 h
- Side direction lights (driving lights required)
- Slow moving vehicle sign
- Special color (one or two)
- Tool set
- Water tank cover (lockable)

EQUIPMENT PACKAGE

CC Plus Package	Included	Optional
Backup alarm	■	
CE sign	■	
Comfort seat	■	
Cup/can holder	■	
Driving lights, right or left handed		■
Dual forward/reverse control		■
Foldable ROPS incl. seat belt	■	
Large Watertank, 190 l	■	
Rotating beacon	■	
Rotating beacon, ignition controlled		■
Spring loaded scrapers		■
Sprinkler timer	■	
Vibr. shut off, front or rear drum	■	
Working lights	■	

Find us locally at www.dynapac.com

We reserve the right to change specifications without notice. Photos and illustrations do not always show standard versions of machines. The above information is a general description only, all information's are supplied without liability.