



TECHNICAL DATA

MASSES

Max. operating mass	1300 kg
Operating mass (incl. ROPS)	1250 kg
Module mass (front/rear)	545 kg/705 kg

COMPACTION

Centrifugal force	16.7 kN
Nominal amplitude	0.4 mm
Static linear load (front/rear)	6.1/7.9 kg/cm
Vibration frequency	70 Hz
Water tank volume	190 l

TRACTION

Speed range	0-8 km/h
Vertical oscillation	±13°
Max. theoretical gradeability	35 %

ENGINE

Manufacturer/Model	Honda GX630R QYD
Type	4-stroke gasoline
Rated power, SAE J1995	14.2 kW (19 hp) @ 3000 rpm
Fuel tank capacity	23 l

HYDRAULIC SYSTEM

Driving	Axial piston pump with variable displacement. 2 radial piston motors with constant displacement.
Vibration	Gear pump/motors with constant displacement.
Steering	Gear pump with constant displacement.
Service brake	Hydrostatic in forward and reverse lever.
Parking/ Emergency brake	Failsafe brake in both drums.

Find us locally at www.dynapac.com

We reserve the right to change specifications without notice. Photos and illustrations do not always show standard versions of machines. The above information is a general description only, all information's are supplied without liability.

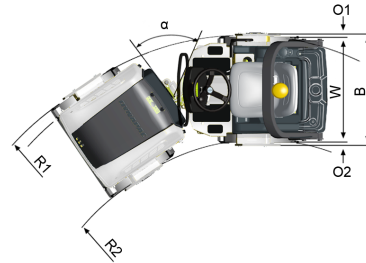
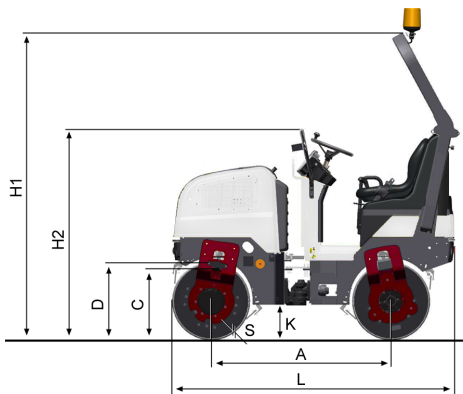

TECHNICAL DATA

DIMENSIONS

A. Wheelbase	1350 mm
B. Width	970 mm
C. Curb clearance	465 mm
D. Drum diameter	584 mm
H1. Height, with ROPS/cab	2300 mm
H2. Height, w/o ROPS/cab	1585 mm
K. Ground clearance	261 mm
L. Length	2107 mm
O1. Overhang, right	35 mm
O2. Overhang, left	35 mm
R1. Turning radius, outside	2700 mm
R2. Turning radius, inside	1800 mm
S. Drum shell thickness	9 mm
W. Drum width	900 mm
α. Steering angle	±34°

STANDARD EQUIPMENT

- Cup Holders, Emergency stop
- Horn
- Hour meter
- Ignition key
- Propulsion in both drums
- Foldable ROPS (incl. seat belt)
- Seat safety switch
- Sliding operator seat
- Towing eyelet (front/rear)
- Vibration on front drum
- Warning light for brakes
- Warning light for hydraulic oil temp

Find us locally at www.dynapac.com

We reserve the right to change specifications without notice. Photos and illustrations do not always show standard versions of machines. The above information is a general description only, all information's are supplied without liability.