



TECHNICAL DATA

MASSES

Operating mass	104 kg
Basic mass	103 kg

COMPACTION

Frequency	90 Hz
Centrifugal force	18 kN
Amplitude	1.63 mm
Water tank volume	7 l

TRACTION

Max. gradeability	30 %
Max. working speed	25 m/min

ENGINE

Manufacturer/Model	Hatz 1B20
Emissions according to	Stage V
Type	Air cooled, diesel
Number of cylinders	1
Fuel consumption /h, avg.	0.7 l
Fuel tank capacity	3 l
Power	3.1 kW @ 3000 rpm

DRIVE SYSTEM

Drive system	Mechanical
--------------	------------

Find us locally at www.dynapac.com

We reserve the right to change specifications without notice. Photos and illustrations do not always show standard versions of machines. The above information is a general description only, all informations are supplied without liability.



DIMENSIONS

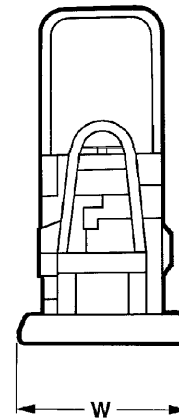
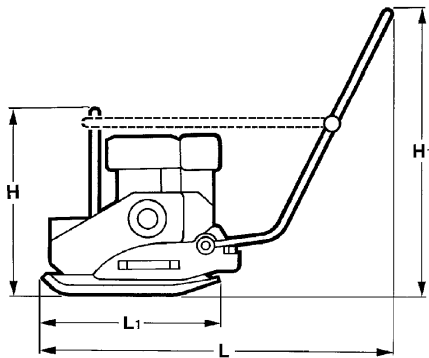

DIMENSIONS

H. Height	650 mm
H1. Height	915 mm
L. Length	1115 mm
L1. Length	560 mm
W. Basic plate width	450 mm

STANDARD FEATURES

- Foldable steering handle with vibration isolation
- Highly wear resistant base plate
- Automatic decompression
- All around protection for V-belt
- Protection frame for powerpack
- Recoil starter
- Carrying handles
- One point lift

OPTIONAL EQUIPMENT

- Water sprinkler system 7l (+7kg)
- Comfort handle
- Puncture proof transport wheels (+4kg)
- Block paving mat
- Service Kit

Find us locally at www.dynapac.com

We reserve the right to change specifications without notice. Photos and illustrations do not always show standard versions of machines. The above information is a general description only, all informations are supplied without liability.