



TECHNICAL DATA

MASSES

Operating mass	122 kg
Basic mass	123 kg

COMPACTION

Frequency	92 Hz
Amplitude	1.11 mm
Water tank volume	13.5 l
Centrifugal force	25 kN

TRACTION

Max. gradeability	30 %
Max. working speed	30 m/min

ENGINE

Manufacturer/Model	Hatz 1B 20
Emissions according to	Stage V/non EPA
Type	Air cooled diesel
Number of cylinders	1
Fuel consumption /h, avg.	0.7 l
Fuel tank capacity	3 l
Power	3.1 kW @ 3000 rpm

DRIVE SYSTEM

Drive system	Mechanical
--------------	------------

Find us locally at www.dynapac.com

We reserve the right to change specifications without notice. Photos and illustrations do not always show standard versions of machines. The above information is a general description only, all informations are supplied without liability.



DIMENSIONS

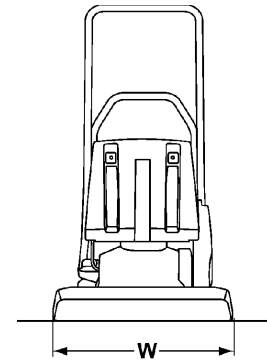
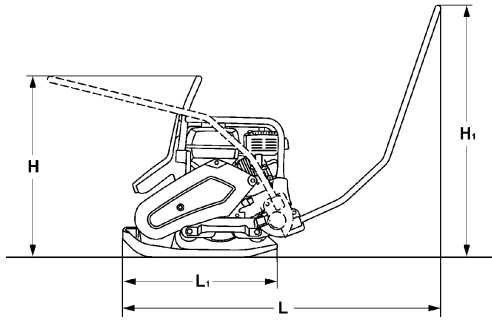

DIMENSIONS

H. Height	708 mm
H1. Height	962 mm
H2. Height	700 mm
L. Length	1084 mm
L1. Length	542 mm
W. Basic plate width	500 mm

STANDARD FEATURES

- Foldable steering handle with vibration isolation
- Highly wear resistant base plate
- Automatic shutdown at low oil level
- All around protection for V-belt
- Protection frame for powerpack
- Recoil starter
- Carrying handles
- One point lift

OPTIONAL EQUIPMENT

- Water sprinkler system 13,5l (+10kg)
- Comfort handle
- Puncture proof transport wheels (+4kg)
- Block paving mat
- Service Kit

Find us locally at www.dynapac.com

We reserve the right to change specifications without notice. Photos and illustrations do not always show standard versions of machines. The above information is a general description only, all informations are supplied without liability.