



## TECHNICAL DATA

### MASSES

Operating mass	54 kg
Basic mass	52 kg

### COMPACTION

Frequency	115 Hz
Centrifugal force	9 kN
Amplitude	0.8 mm

### TRACTION

Max. gradeability	20 %
Max. working speed	25 m/min

### ENGINE

Manufacturer/Model	Honda GXR120
Emissions according to	EU Stage V
Type	Air cooled, Petrol
Number of cylinders	1
Fuel tank capacity	0.8 l
Power	1.8 kw @ 3500 rpm

### DRIVE SYSTEM

Drive system	Mechanical
--------------	------------

Find us locally at [www.dynapac.com](http://www.dynapac.com)

We reserve the right to change specifications without notice. Photos and illustrations do not always show standard versions of machines. The above information is a general description only, all informations are supplied without liability.



## DIMENSIONS

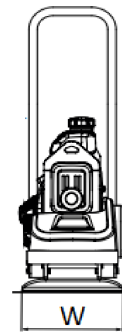
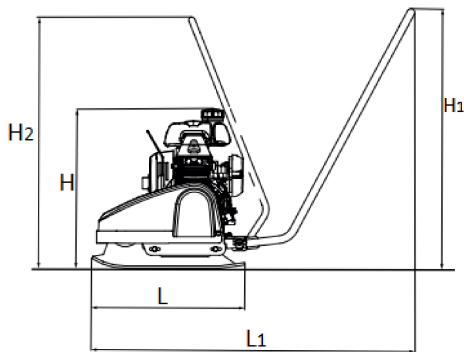

### DIMENSIONS

H. Height	520 mm
H1. Height	870 mm
H2. Height	840 mm
L. Length	500 mm
L1. Length	1110 mm
W. Basic plate width	300 mm

### STANDARD FEATURES

- Foldable steering handle with vibration isolation
- Highly wear resistant base plate
- Automatic shutdown at low oil level
- All around protection for V-belt
- Recoil starter
- Carrying handles
- One point lift

### OPTIONAL EQUIPMENT

- Block paving mat
- Service Kit

Find us locally at [www.dynapac.com](http://www.dynapac.com)

We reserve the right to change specifications without notice. Photos and illustrations do not always show standard versions of machines. The above information is a general description only, all informations are supplied without liability.