



TECHNICAL DATA

MASSES

Basic mass	137 kg
Operating mass	140 kg

COMPACTION

Amplitude	1.31 mm
Centrifugal force	25 kN
Frequency	85 Hz
Water tank volume	12 l

TRACTION

Max. gradeability	30 %
Max. working speed	25 m/min

ENGINE

Manufacturer/Model	Honda GX 160
Emissions according to	EU Stage V /US EPA
Type	Air cooled gasoline
Number of cylinders	1
Fuel consumption /h, avg.	1.1 l
Fuel tank capacity	3 l
Power	3.6 kW @ 3600 rpm

DRIVE SYSTEM

Drive system	Mechanical
--------------	------------

Find us locally at www.dynapac.com

We reserve the right to change specifications without notice. Photos and illustrations do not always show standard versions of machines. The above information is a general description only, all informations are supplied without liability.



DIMENSIONS

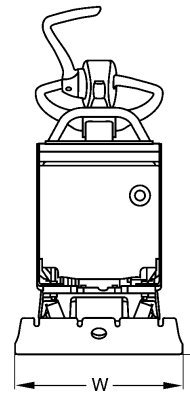
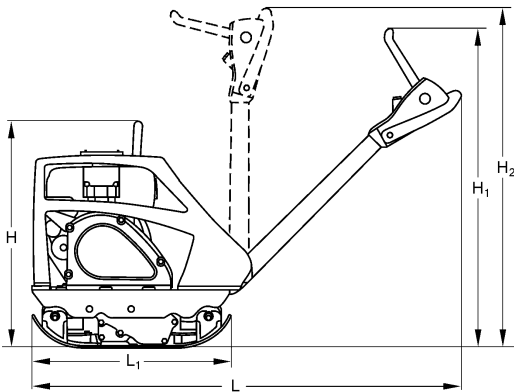

DIMENSIONS

H. Height	660 mm
H1. Height	930 mm
H2. Height	1030 mm
L. Length	1274 mm
L1. Length	650 mm
W. Basic plate width	500 mm

STANDARD FEATURES

- Control handle with vibration isolation
- Height adjustable control lever
- Control lever lock in transport and working position
- Reverse drive protection
- Highly wear resistant base plate
- All around protection hood
- All around protection for V-belt
- Automatic shutdown at low oil level
- One point lift
- Recoil starter

OPTIONAL EQUIPMENT

- Block paving mat
- Puncture proof transport wheels (+4kg)
- Water sprinkler system 12l (+13kg)
- Service Kit

Find us locally at www.dynapac.com

We reserve the right to change specifications without notice. Photos and illustrations do not always show standard versions of machines. The above information is a general description only, all informations are supplied without liability.