



### LONGEVITY

- Wear resistance characteristics of HARDOX maximizes the life-time of the base-plate.
- Open-style construction of the base-plate prevents the stones from getting stuck, thus reducing the wear & tear.

### DURABILITY

- Robust all-around protection cage with solid one-point lift.

### COMFORT

- Low levels of hand arm vibration is made possible by the vibration damping solution.

### PRACTICAL

- Easy-open flaps to access daily check points like fuel tank cap, filter.

## TECHNICAL DATA

### MASSES

Operating mass 337 kg

### DIMENSIONS

Compaction width 600 mm

### COMPACTION

Centrifugal force 55 kN

Frequency 72 Hz

### TRACTION

Max. gradeability 20 %

Max. working speed 25 m/min

### ENGINE

Manufacturer/Model Honda GX390

Emissions according to StageV & US EPA

Fuel type Petrol

Fuel tank capacity 6.10 l

Power 6,4 kW

### DRIVE SYSTEM

Drive system Mechanical

Find us locally at [www.dynapac.com](http://www.dynapac.com)

We reserve the right to change specifications without notice. Photos and illustrations do not always show standard versions of machines. The above information is a general description only, all informations are supplied without liability.



### LONGEVITY

- Wear resistance characteristics of HARDOX maximizes the life-time of the base-plate.
- Open-style construction of the base-plate prevents the stones from getting stuck, thus reducing the wear & tear.

### DURABILITY

- Robust all-around protection cage with solid one-point lift.

### COMFORT

- Low levels of hand arm vibration is made possible by the vibration damping solution.

### PRACTICAL

- Easy-open flaps to access daily check points like fuel tank cap, filter.

## DIMENSIONS

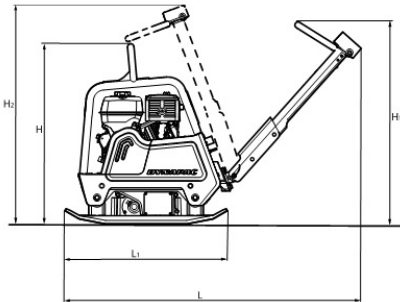

### DIMENSIONS

H. Height	982 mm
H1. Height	1,005 mm
H2. Height	1,225 mm
L. Length	1,650 mm
L1. Length	884 mm
W. Basic plate width	600 mm
W1. Machine width	532 mm

### STANDARD FEATURES

- Comfort control handle with vibration isolation
- Control lever lock in transport position
- Reverse drive protection
- Highly wear resistant hardox base plate
- Protection hood
- All around protection for V-belt
- One point lift
- Recoil starter

### OPTIONAL EQUIPMENT

- Block paving mat
- Service Kit

Find us locally at [www.dynapac.com](http://www.dynapac.com)

We reserve the right to change specifications without notice. Photos and illustrations do not always show standard versions of machines. The above information is a general description only, all informations are supplied without liability.