



- Intuitive PaveManager 2.0 user interface
- Integrated advanced leveling solutions
- AddTraxxion anti-slip 6x6 undercarriage
- Perfect overview with slidable cabin
- Efficient drive train

TECHNICAL DATA

MASSES

Basic weight (incl. standard screed)	18 t
--------------------------------------	------

DIMENSIONS

Front ramp angle	17°
Working width, max.	9 m
Working width, minimum (with reducing shoe)	2.05 m
Basic width	2.55 m

CAPACITY

Placement thickness (max)	300 mm
Theoretical placement capacity	750 t/h

MATERIAL HOPPER

Capacity	6.0 m³
Dumping height (center/outside)	574 mm /587 mm
Hopper width, internal	3.29 m

TRACTION

Maximum paving speed	30 m/min
Transport speed	20.0 km/h

ENGINE

Manufacturer/Model	Cummins QSB6.7-C173
Emissions according to	Stage V
Rated power, SAE J1995	129 kW @ 2200 rpm
Electrical system	24 V
Fuel tank capacity	315 l

ENGINE

Manufacturer/Model	Cummins QSB6.7-C173
Emissions according to	Stage IIIA (Tier 3)
Rated power	129 kW @ 2200 rpm
Peak Power	133 kW
Electrical system	24 V
Fuel tank capacity	306 l

UNDERCARRIAGE

Tyre size	445/80R25
Front wheels	4 x 560/300-390
Turning radius (inside)	2.48 m
Turning radius (outside)	6.07 m

CONVEYOR

Conveyor type	Dual bar feeder
Conveyor control	The independent conveyor with proportional control
Conveyor width	2x 580 mm

AUGER

Auger diameter	380 mm
Auger control	Automatic with ultrasonic sensors

Find us locally at www.dynapac.com

We reserve the right to change specifications without notice. Photos and illustrations do not always show standard versions of machines. The above information is a general description only, all informations are supplied without liability.



- Intuitive PaveManager 2.0 user interface
- Integrated advanced leveling solutions
- AddTraxxion anti-slip 6x6 undercarriage
- Perfect overview with slidable cabin
- Efficient drive train

DIMENSIONS

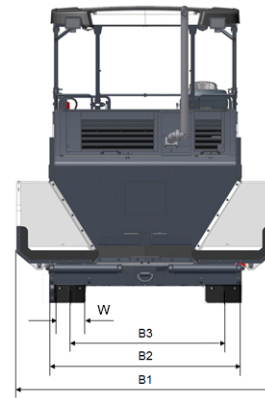
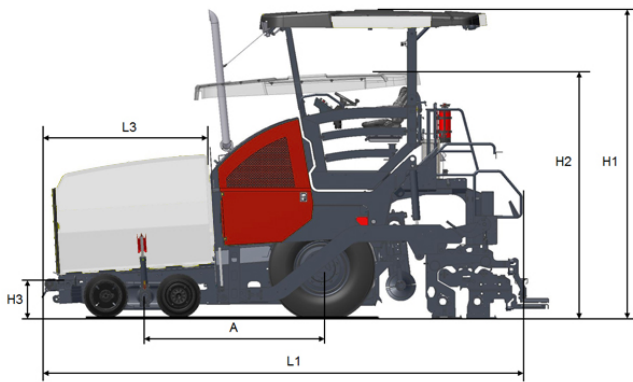

DIMENSIONS

A. Wheelbase	2.24 m
B1. Width, max.	3.25 m
B2. Width, standard	2.55 m
B3. Width, wheel track	2.05 m
H1. Height, max.	3.90 m
H2. Height, transport	3.10 m
H3. Height	0.49 m
L1. Length	6.10 m
L3. Length, hopper	2.12 m
W. Width, wheels	0.30 m

STANDARD EQUIPMENT

Fixed, pivotable

OPTIONAL EQUIPMENT

Hydraulic damping and stepless adjustable (20cm) with automatic function

Find us locally at www.dynapac.com

We reserve the right to change specifications without notice. Photos and illustrations do not always show standard versions of machines. The above information is a general description only, all informations are supplied without liability.

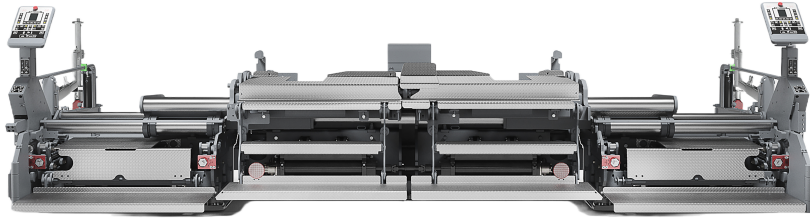

COMPATIBLE SCREEDS

V5100 TV / TV E



V6000 TV / TV E

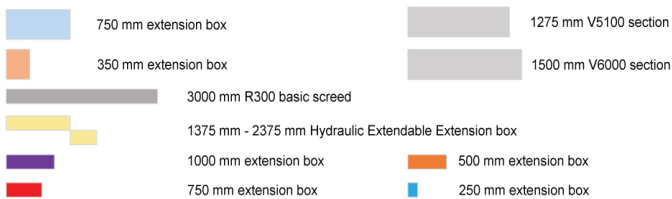

Find us locally at www.dynapac.com

We reserve the right to change specifications without notice. Photos and illustrations do not always show standard versions of machines. The above information is a general description only, all informations are supplied without liability.