



- Integrated advanced leveling solutions
- Big hopper volume
- Perfect overview with slidable cabin
- Increased traction due to longer tracks

TECHNICAL DATA

MASSES

Weight 22.5 t

DIMENSIONS

Basic width 2.55 m
 Working width, max. 10 m
 Working width, minimum (with reducing shoe) 2.05 m
 Front ramp angle 13°

CAPACITY

Placement thickness (max) 360 mm
 Theoretical placement capacity 800 t/h

MATERIAL HOPPER

Capacity 7.0 m³ (17 t)
 Dumping height (center/outside) 525 mm /530 mm
 Hopper width, internal 3.29 m

TRACTION

Paving speed 20 m/min
 Transport speed 3.0 km/h

ENGINE

Manufacturer/Model Cummins QSB 6.7-C200
 Emissions according to EU Stage IIIA
 Rated power, SAE J1995 142 kW (193 Hp) @ 2200 rpm
 Electrical system 24 V
 Fuel tank capacity 337 l

ENGINE

Manufacturer/Model Cummins B6.7CSIV201F
 Emissions according to China IV
 Rated power, SAE J1996 149 kW @ 2200 rpm
 DEF tank capacity 37 l
 Electrical system 24 V
 Fuel tank capacity 362 l

UNDERCARRIAGE

Crawler length 3.36 m
 Crawler width 320 mm
 Drive Technology Hydrostatic

CONVEYOR

Conveyor type Dual bar feeder
 Conveyor control Automatic with limit switches
 Conveyor width 2x 655 mm

AUGER

Auger diameter 380 mm
 Auger control Automatic with ultrasonic sensors

Find us locally at www.dynapac.com

We reserve the right to change specifications without notice. Photos and illustrations do not always show standard versions of machines. The above information is a general description only, all informations are supplied without liability.



- Integrated advanced leveling solutions
- Big hopper volume
- Perfect overview with slidable cabin
- Increased traction due to longer tracks

DIMENSIONS

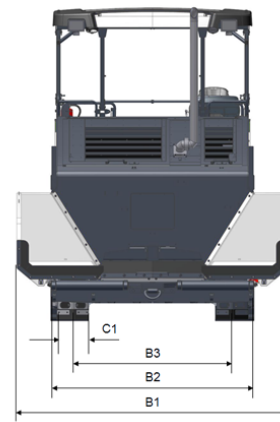
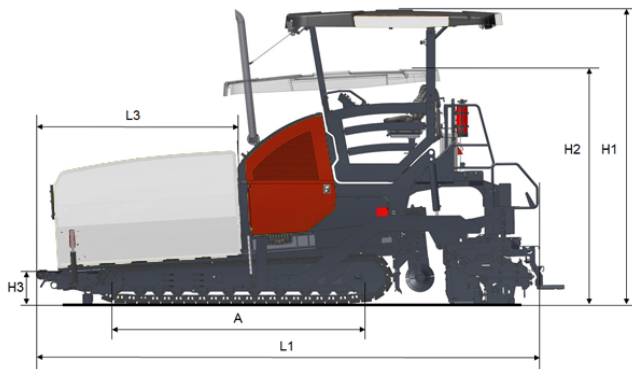

DIMENSIONS

A. Axle track	3.36 m
B1. Width, max.	3460 mm
B2. Width, standard	2.55 m
B3. Width, center of tracks	1.99 m
C1. Track width	0.32 m
H1. Height, max.	3.90 m
H2. Height, transport	3.10 m
H3. Height	0.46 m
L1. Length	6.63 m
L3. Length, hopper	2.60 m

Find us locally at www.dynapac.com

We reserve the right to change specifications without notice. Photos and illustrations do not always show standard versions of machines. The above information is a general description only, all informations are supplied without liability.

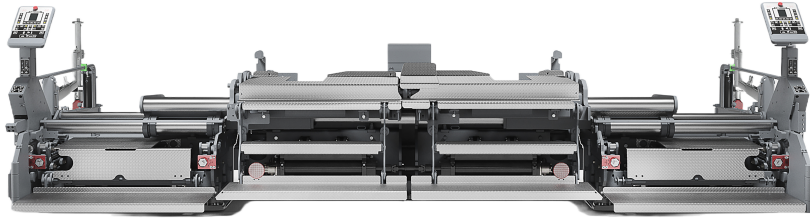

COMPATIBLE SCREEDS

V5100 TV / TV E



V6000 TV / TV E



R300 TV / TV E

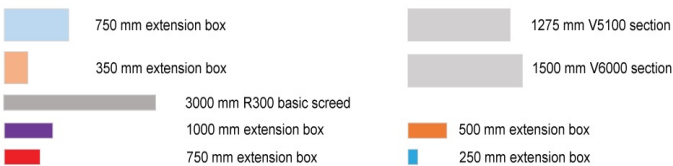
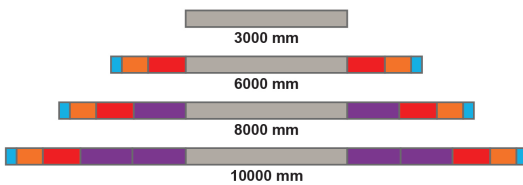

Find us locally at www.dynapac.com

We reserve the right to change specifications without notice. Photos and illustrations do not always show standard versions of machines. The above information is a general description only, all informations are supplied without liability.