



- Intuitive PaveManager 2.0 user interface
- Integrated advanced leveling solutions
- Big hopper volume
- Perfect overview with slidable cabin
- Increased traction due to longer tracks

TECHNICAL DATA

MASSES

Weight (incl. standard screed) 20 t

DIMENSIONS

Basic width 2.55 m
Working width, max. 14 m
Working width, minimum (with reducing shoe) 2.05 m
Front ramp angle 13°

CAPACITY

Placement thickness (max) 360 mm
Theoretical placement capacity 1100 t/h

MATERIAL HOPPER

Capacity 7.0 m³
Dumping height (center/outside) 525 mm /530 mm
Hopper width, internal 3.29 m

TRACTION

Maximum paving speed 28 m/min
Transport speed 4.0 km/h

ENGINE

Manufacturer/Model Cummins QSB6.7-C260
Emissions according to EU Stage IIIA
Rated power, SAE J1995 194 kW @ 2200 rpm
Electrical system 24 V
Fuel tank capacity 337 l

ENGINE

Manufacturer/Model Cummins B6.7CSIV264F
Emissions according to China IV
Rated power, SAE J1996 194 kW @ 2200 rpm
DEF tank capacity 37 l
Electrical system 24 V
Fuel tank capacity 362 l

ENGINE

Manufacturer/Model Cummins QSB6.7-C260
Emissions according to EU Stage V /US EPA t4f
Rated power, SAE J1995 194 kW @ 2200 rpm
DEF tank capacity 37 l
Electrical system 24 V
Fuel tank capacity 362 l

UNDERCARRIAGE

Crawler length 3.36 m
Crawler width 320 mm
Drive Technology Hydrostatic

CONVEYOR

Conveyor type Dual bar feeder
Conveyor control Automatic with limit switches
Conveyor width 2x 655 mm

AUGER

Auger diameter 500 mm
Auger control Automatic with ultrasonic sensors

Find us locally at www.dynapac.com

We reserve the right to change specifications without notice. Photos and illustrations do not always show standard versions of machines. The above information is a general description only, all informations are supplied without liability.



- Intuitive PaveManager 2.0 user interface
- Integrated advanced leveling solutions
- Big hopper volume
- Perfect overview with slidable cabin
- Increased traction due to longer tracks

DIMENSIONS

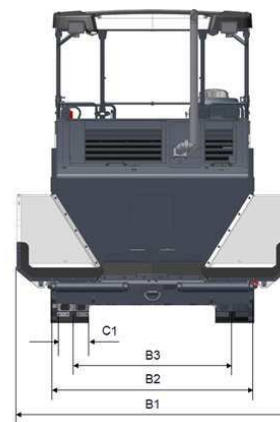
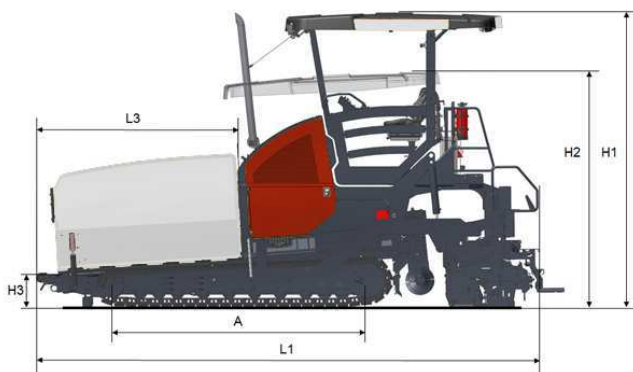

DIMENSIONS

A. Axle track	3.36 m
B1. Width, max.	3.47 m
B2. Width, standard	2.55 m
B3. Width, center of tracks	1.99 m
C1. Track width	0.32 m
H1. Height, max.	3.90 m
H2. Height, transport	3.10 m
H3. Height	0.46 m
L1. Length	6.63 m
L3. Length, hopper	2.60 m

Find us locally at www.dynapac.com

We reserve the right to change specifications without notice. Photos and illustrations do not always show standard versions of machines. The above information is a general description only, all informations are supplied without liability.

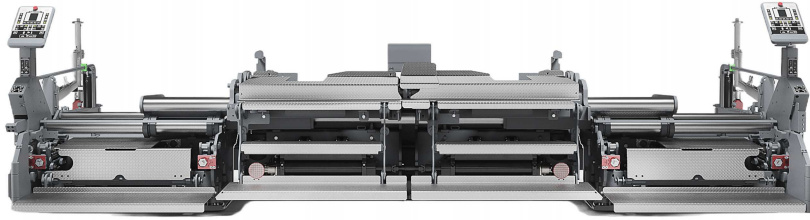

COMPATIBLE SCREEDS

V5100 TV / TV E / TH E



V6000 TV / TV E / TH E



R300 TV / TV E

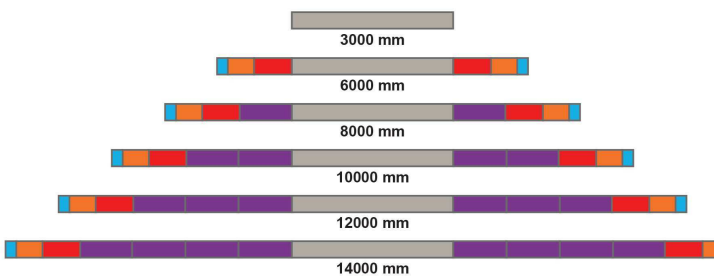

R300 TV HEE / TV E HEE

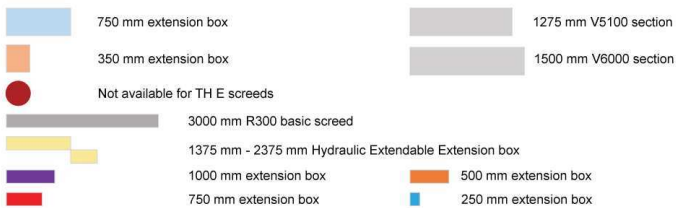
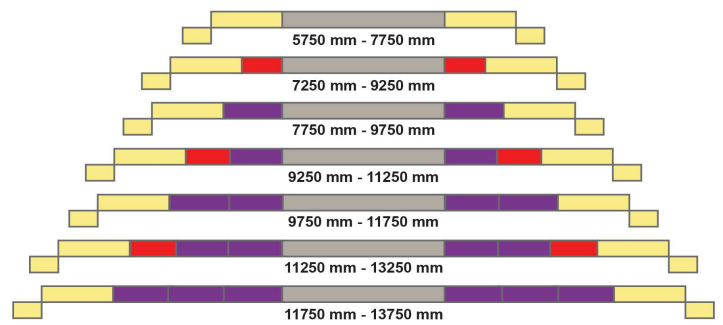

Find us locally at www.dynapac.com

We reserve the right to change specifications without notice. Photos and illustrations do not always show standard versions of machines. The above information is a general description only, all informations are supplied without liability.